

# M200M-T-W-N

Data logger with remote monitoring and cloud support for Wifi network

## - Features

- High Performance Cortex M3 32-bit ARM
- Data Logger on SD card
- Real-time data monitoring
- Internal webpage for online monitoring
- Protocols: Modbus RTU & TCP-IP
- 6 Analog inputs: 4-20 mA, 0-10 V
- 4 Digital inputs
- 4 Digital outputs
- Data transmission for Wifi network
- Mounting: Wall-mounted



## - Introduction

M200M-T-W-N is the IoT Gateway product line built and developed by Saigon Technolog. It is capable of connecting multiple field devices (sensors, pumps, fans...) by input and output such as Analog (4-20 mA, 0-10 V), Digital, RS-485 and transfer data to cloud storage & machine Web server over Wifi network. Allows users to manage alarms and remote monitoring in real time using TCP-IP protocol.

The product features a compact, industry-standard design that's rugged enough to withstand the harsh conditions of industrial environments. The installation has been standardized, neat and fast. The operation configuration of the system is simple, flexible, can be done locally or remotely.

M200M-T-W-N supports 256MB Flash memory, micro SD card slot expands up to 8GB, multi-tasking real-time operating system. The combined use of these data managers with the IoT Platform solution produced by SGTEC will complete the data management on Web / App Mobile anytime and anywhere by phone, Ipad, Laptop...

## - Firmware

<b>Data collection</b> <ul style="list-style-type: none"> <li>• Collect data from Analog and Digital inputs</li> <li>• Collect data from RS485 ports</li> <li>• Acts as a Master device and collects data from one or more other Modbus RTU devices</li> </ul>	<b>Data logging</b> <ul style="list-style-type: none"> <li>• Flash memory up to 256Mb</li> <li>• Features automation, control and remote monitoring</li> <li>• Function to get data from memory cards via USB port</li> </ul>
<b>Data communication</b> <ul style="list-style-type: none"> <li>• Data transmission over Wifi network</li> <li>• Protocols: Modbus RTU &amp; TCP-IP</li> </ul>	<b>Configure Settings</b> <ul style="list-style-type: none"> <li>• By software via USB Serial Port (MEES Config by SG Technolog)</li> </ul>

## - Application Example

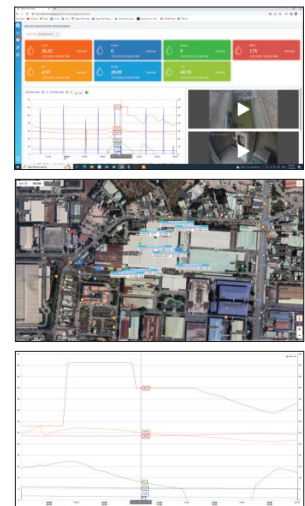
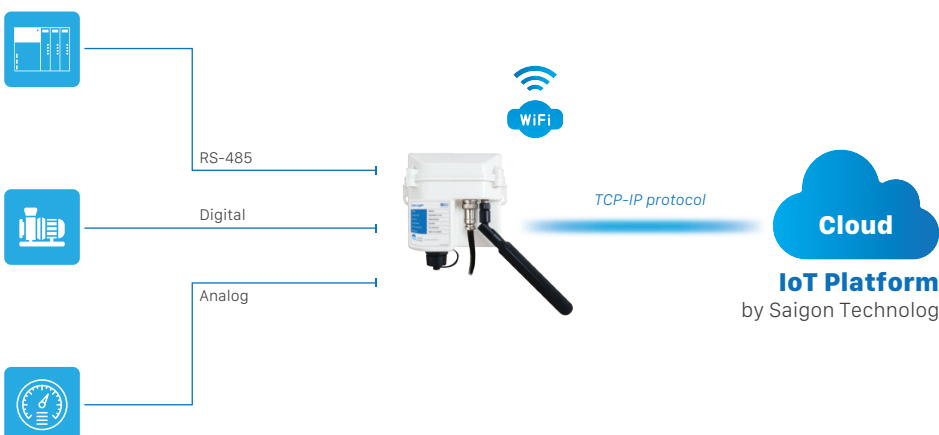

### - Specifications

Control system	
MCU	Cortex M3 32-bit ARM
Power Supply	12...24 VDC
Protection Degree	IP67
USB port	Support 1 x USB type-A 2.0
Memory	Chip Flash 256MB
Sd card	Support up to 8Gb
Communication	
Protocols	Modbus RTU & TCP-IP
Interfaces	<ul style="list-style-type: none"> <li>Support 1 x RS-485 master: connect with max. 3 slave</li> <li>Data transmission over Wifi network</li> </ul>
Analog input	
Channels	6
Type	Voltage: 0...10 V Current: 0...20 mA, 4...20 mA
Resolution	24-bit
Digital/ Pulse input	
Channels	4
Digital output	
Channels	4
General	
Dimensions (LxWxH)	120mm x 120mm x 65mm
Operating Temp.	-5...55°C
Mounting	Wall-mounted

### - Wiring

M200M-T-W-N with simplified wiring diagram. Users can conveniently choose from 12VDC to 24VDC power supply. Follow the diagram below for wiring.

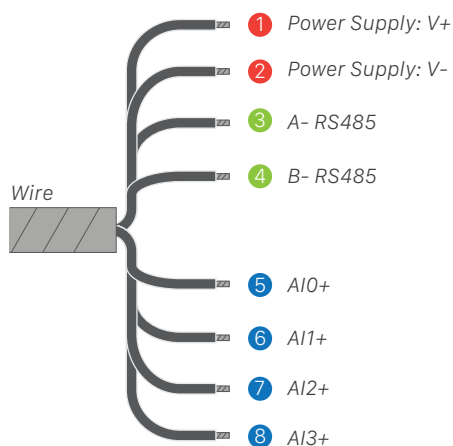

### - Dimensions

Drawings and dimensions (all dimensions in millimeters)

